

# Design Considerations for a Variable Angle Absolute Reflectance Accessory For the LAMBDA 950/850/650 UV/Vis/NIR and UV/Vis Spectrophotometers



## Introduction

The accurate measurement of specular reflectance over a substantial range of angles and a wide range of wavelengths from the UV through NIR is a prerequisite to the design and manufacture of a wide variety of modern optical components. In designing a system

for making these measurements, PerkinElmer set out to address the various limitations that effect currently available commercial spectrophotometer accessories. This application note discusses these limitations and describes how we have attempted to reduce them with the design of a

variable angle absolute reflectance accessory. This device provides absolute reflectance over a wide range of angles of incidence for samples sizes from 5 mm to greater than 150 mm.

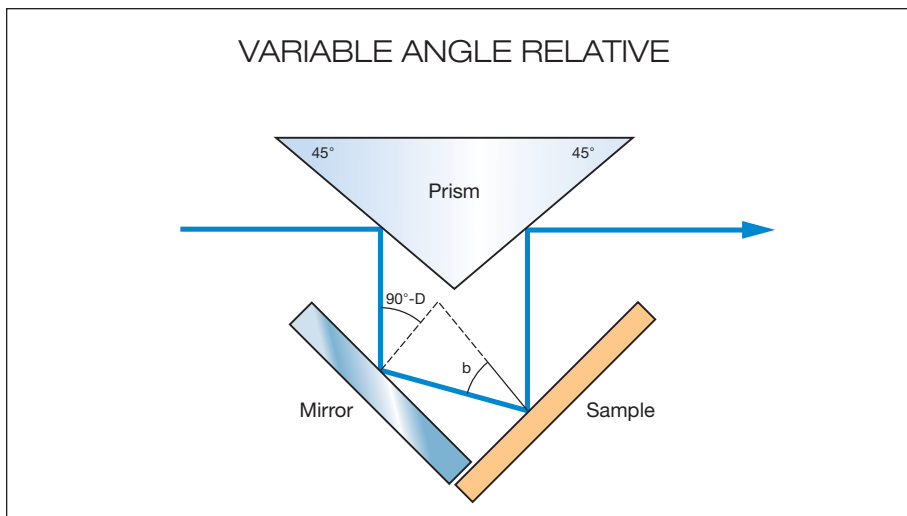

Figure 1. A variable angle relative reflectance sampling arrangement.

### Requirements

One of the primary design objectives of the variable angle absolute reflectance accessory was to address market requirements for the best possible accuracy, versatility, and convenient operation at an acceptable cost, without having to make any compromises.

For routine measurements, an accuracy of 1% with repeatability of 0.2% was identified as an appropriate target specification. The desired measurement range was 250 to 3200 nm with the angle of incidence variable between 8 and 68 degrees. Due to the increased need to measure small samples, the minimum size was specified to be 5 mm, but at the same time, the need to handle large samples continues. It is difficult to specify convenience, but the need is for anyone used to handling optical components to be able to achieve the specified performance with reasonable care.

### Current methods

There are two classes of measurement, relative and absolute. Relative measurements require a reference mirror of known reflectance. The

sample and reference are measured under identical conditions and the ratio of these measurements, after dark signal correction, gives the required value. A typical arrangement for variable angle reflectance

is shown in Figure 1. The major problem with this approach is the need for the reference mirror, with the possibilities of ageing and contamination creating uncertainty. At the same time, imperfections in the sample and variations in the sample positioning introduce errors associated with beam and detector homogeneity.

Absolute measurements avoid the need for a reference mirror at the expense of introducing more complex optical arrangements. The principle is to make two measurements that differ only in that one includes reflection at the sample. Provided that propagation losses are identical, the ratio of the two values leads to the required reflectance. Current commercial spectrophotometer accessories are based primarily on either the V-N or V-W configura-

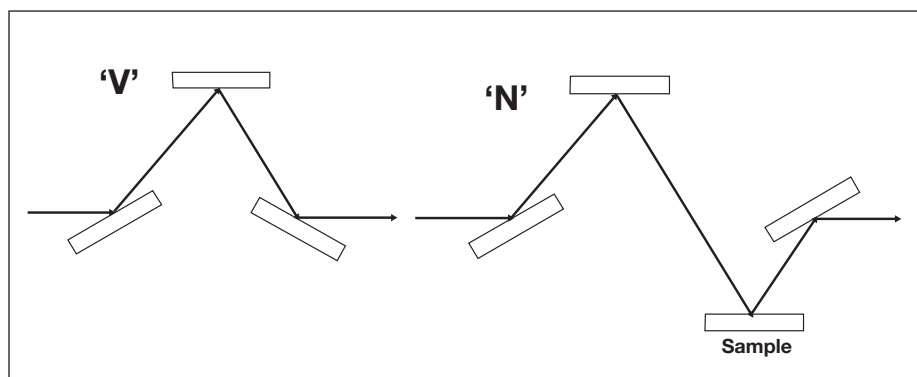

Figure 2. The V-N absolute reflectance geometry (simplified).

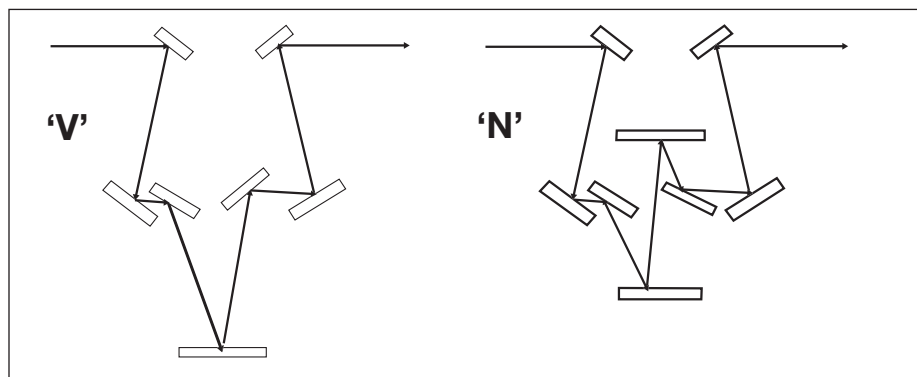

Figure 3. The V-N absolute reflectance geometry.

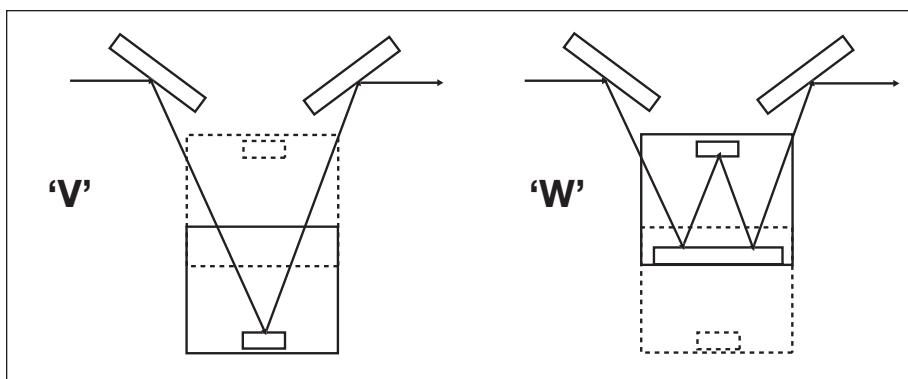

Figure 4. The V-W absolute reflectance sampling geometry.

tions, named for their distinctive optical paths.

In the V-N arrangement, rotation and translation of the output mirror allows a single reflection at the sample to be introduced without altering the direction of the output beam (Figure 2). In practice, more elaborate schemes are used to maintain the length of the optical path through the accessory (Figure 3). However, the output beam is inverted between the two configurations. This makes the accuracy critically dependent upon alignment and the beam and detector homogeneity. To overcome these problems an integrating sphere detector is often needed.

The 'Strong' V-W arrangement introduces two reflections at the sample (Figure 4). This has been seen as advantageous for samples with high reflectivity since the signal change to be measured is twice as large. However, the need for two reflections makes this unsuitable for small samples, especially at higher angles of incidence. It is also unsuitable for samples of low reflectivity. It is sometimes suggested that these problems can be addressed by using a mirror of known reflectivity alongside the sample to provide one of the reflections, but this is very inconvenient and removes the absolute nature of the measurement.

Although there is no beam inversion the alignment is again critical.

Although these absolute accessories are simple in principle, in practice they do not readily achieve the highest accuracy. Manufacturing tolerances limit the matching of the two configurations so that realignment between the configurations may be needed. This is typically done by incorporating a visible laser and adjusting the moveable mirror to maintain the spot from this at a constant position on a screen. The configuration of a commercial variable angle V-W accessory using this approach is shown in Figure 5. Although this method is successful, some users regard the inconvenience of the absolute technique as impractical for a day-to-day calibration service.

### Constraints

The principal constraint for the absolute reflectance accessories is to match the output beam between two configurations. This matching is required because the beam intensity is not uniform and the PbS detector responsivity varies across its area. Experience with current systems suggests that normal mechanical tolerances result in arrangements that require frequent readjustment. The usual way to address this has

been to use an integrating or collecting sphere to scramble the light input to the detector. For the present development an alternative method for light scrambling was investigated. This is to use a cylindrical light pipe with multiple internal reflections as the light is propagated.

As well as the performance in light scrambling, the practicability of implementing this alternative has to be considered. The issues here are convenience and cost. For both simplicity and reproducibility, it is highly desirable that samples should be measured in a horizontal position. While a light pipe could represent a lower cost it might also result in an unacceptably large optical arrangement.

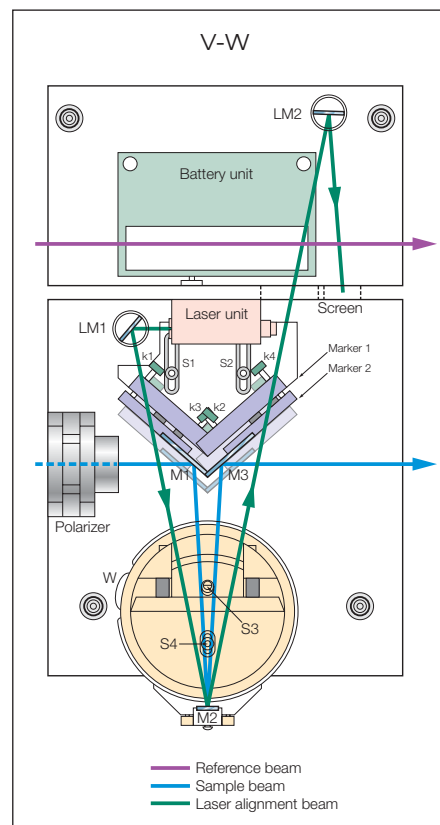

Figure 5. A commercial variable angle V-W accessory.

## Investigating light scrambling performance

Two types of light pipe were considered: a hollow gold-plated tube where light is guided by reflection at the gold walls; and a glass rod which guides light by total internal reflection. As well as modeling the uniformity of output for an inhomogeneous beam, the sensitivity to lateral displacement and tilt of the beam were investigated. The results showed that a gold-plated light pipe would be too sensitive to displacement of the beam, but that a solid glass rod, 50mm long, has suitable characteristics. While an integrating sphere can achieve very good beam scrambling, the light pipe approach offers much higher optical throughput. Following this investigation, the glass rod light scrambler was adopted. To minimise the overall size of the optics this is incorporated in a Z-fold configuration with simple spherical mirrors to focus the input beam on to one end of the light pipe and then focus the output on to the detector.

## The Universal Reflectance Accessory (URA): an innovative system design

The basic operation of the system consists of first making a baseline measurement and then a sample measurement that involves one additional reflection at the sample. Switching between baseline and sample configurations involves rotating one mirror and translating the detector assembly automatically. This is illustrated below for measurement at 68 degree incidence (Figures 6 and 7). The input mirror rotates to direct the beam onto the measurement sample. At the same time the detector assembly is translated to maintain the same

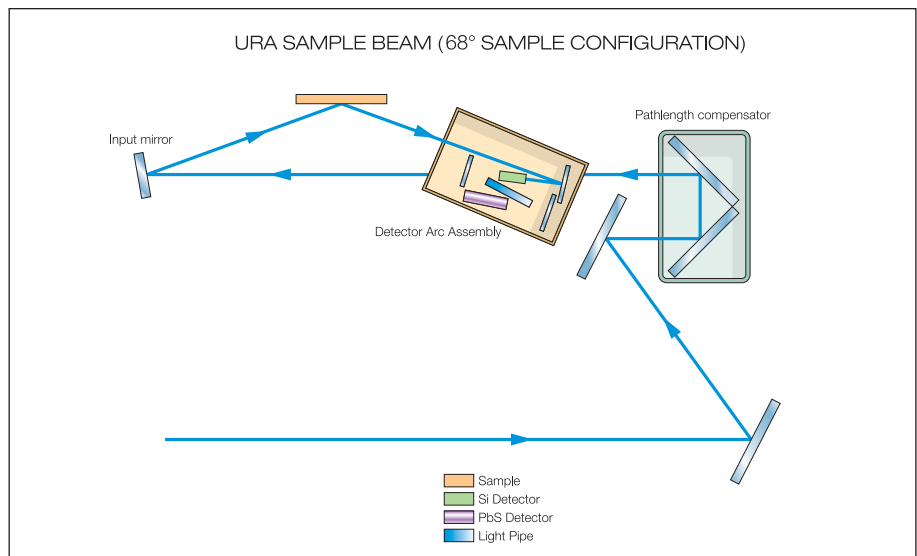

Figure 6. The URA sample measurement configuration at 68°.

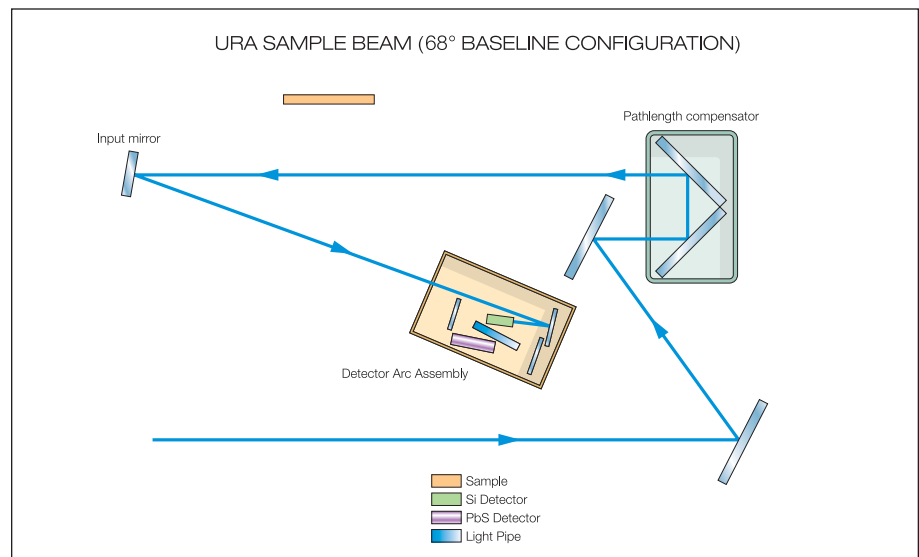

Figure 7. The URA baseline measurement configuration at 68°.

relationship with the input beam. The total optical path remains the same so that the ratio of the two measurements gives the reflectance of the sample.

For measurements at different angles of incidence the input mirror is translated and rotated with the detector arc assembly being rotated, again under software control. The

baseline and sample configurations for 8 degree incidence are illustrated below (Figures 8 and 9).

There are additional optics to maintain the pathlength as the input mirror is moved for different angles of incidence. In addition there is a silicon detector to cover the UV-visible range. The beam scrambling light pipe is not

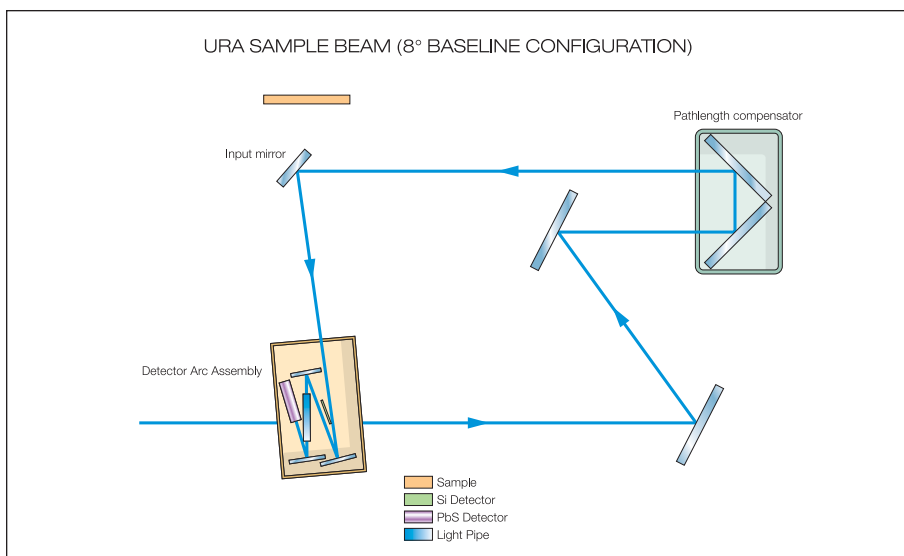

Figure 8. The URA baseline measurement configuration at 8°.

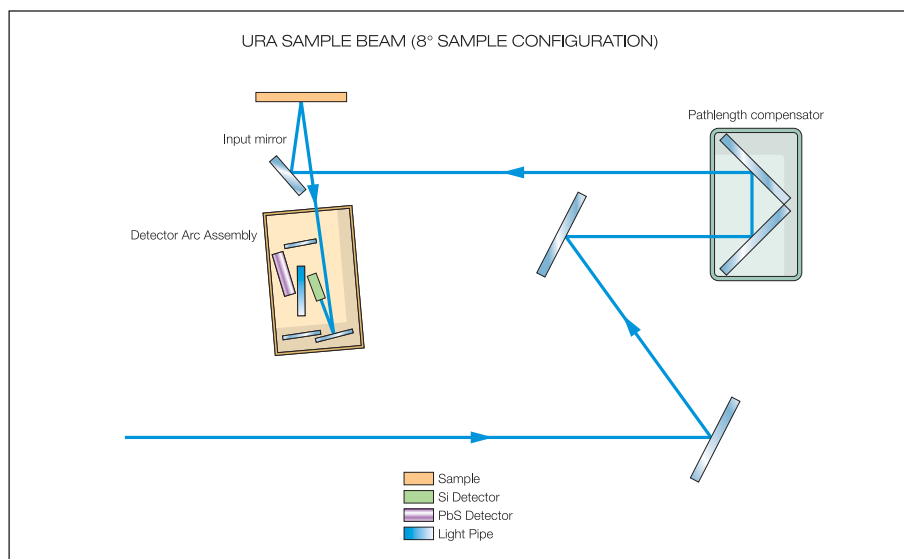

Figure 9. The URA sample measurement configuration at 8°.

required with the silicon detector which is extremely uniform. Switching between the detectors is automatic. The complete optical scheme with the various motions that are involved is shown in the previous figures. Despite the apparent complexity all the user sees is the aperture over which the sample is placed. No adjustments

are required in order to make measurements over the full range of angles of incidence from 8 to 68 degrees.

### Conclusion

There are several significant advantages to the URA design, compared with traditional approaches. Firstly,

any measurement angle can be selected from within the system software. This allows reproducible measurement at multiple angles without manual adjustment to the optics or the sample. Only one accessory is required to cover the full range of angles between 8 and 68 degrees.

The accessory also switches automatically between sample and baseline configurations without manual intervention. Additionally, the sample is simply placed on a horizontal sampling plate rather than being clamped vertically. This increases reproducibility and prevents delicate samples being scratched by the clamping mechanism. The whole URA optical unit is housed within a compact sampling module which protects the optics from dirt and dust and ensures that optical alignment is maintained. This unit can easily be interchanged with other sampling modules such as integrating spheres and transmission optics when other types of samples need to be measured. (Figure 10.)



Figure 10. The URA sampling module can be simply interchanged depending on sampling need.

**PerkinElmer Life and  
Analytical Sciences**  
710 Bridgeport Avenue  
Shelton, CT 06484-4794 USA  
Phone: (800) 762-4000 or  
(+1) 203-925-4602  
[www.perkinelmer.com](http://www.perkinelmer.com)



---

For a complete listing of our global offices, visit [www.perkinelmer.com/lasoffices](http://www.perkinelmer.com/lasoffices)

©2004 PerkinElmer, Inc. All rights reserved. The PerkinElmer logo and design are registered trademarks and LAMBDA is a trademark of PerkinElmer, Inc. All other trademarks not owned by PerkinElmer, Inc. or its subsidiaries that are depicted herein are the property of their respective owners. PerkinElmer reserves the right to change this document at any time and disclaims liability for editorial, pictorial or typographical errors.